



# 6" SQUARE DIRECT PAR SERIES



## SPC0609SQINC - CEILING MOUNT

### APPLICATION

6" square cylinder series for use with incandescent PAR lamps.

### FEATURES

Spectrum Surface Solutions series provides traditional architectural style with high performance energy efficient illumination. Rugged design with flexible mounting, finish and lamping options make these extremely versatile fixtures.

### FINISH

Multi-stage polyester powder-coat process applied on our dedicated paint lines. A wide variety of standard and custom finishes are available. All exposed materials are chromate pretreated to resist corrosion.

### ELECTRONICS

120V socket standard.

### CONSTRUCTION

Extruded .125 6063 aluminum fixture housing. Specular primary optical reflectors provide high efficiency illumination. Stainless steel hardware with galvanized steel brackets to resist corrosion. Formed .063 aluminum reflector/trim finished to specification

### CODE COMPLIANCE

ETL listed for damp locations. Manufactured and tested to UL standard No. 1598.

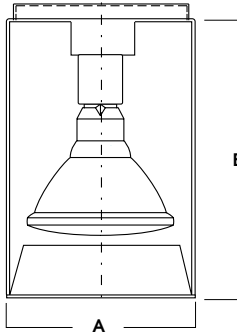

| A                  | B               |
|--------------------|-----------------|
| 6.0 SQ<br>152.4 mm | 9.5<br>241.3 mm |

| SERIES       | LED LAMP              | TRIM                | MOUNTING <sup>1</sup>                                                                                                                                                      | FINISH <sup>3</sup>                                            |
|--------------|-----------------------|---------------------|----------------------------------------------------------------------------------------------------------------------------------------------------------------------------|----------------------------------------------------------------|
| SPC0609SQINC | PAR30<br>PAR38<br>R30 | 0305-PT<br>MW<br>MB | HM <sup>2</sup> Hang Straight<br>PM <sup>2</sup> Rigid Pendant Mount<br>AT <sup>2</sup> Hang Straight All Thread<br>CD <sup>2</sup> Cord / Cable Mount<br>SM Surface Mount | MW <sup>4</sup> Matte White                                    |
|              |                       |                     |                                                                                                                                                                            | MB <sup>4</sup> Matte Black                                    |
|              |                       |                     |                                                                                                                                                                            | PT <sup>4</sup> Platinum Silver                                |
|              |                       |                     |                                                                                                                                                                            | CC Custom Color                                                |
|              |                       |                     |                                                                                                                                                                            | See Page 4<br>for Full Range of<br>Color Options<br>(83-90095) |

**EXAMPLE:** SPC0609SQINC/PAR38/0305PT/HM36/MW

**NOTES:**  
 1 See Mounting Page for Details on Components and Finishes    2 Specify Length in Inches: See Mounting Page for Available Lengths    3 See Color Page for More Options/Consult Factory for Special Finishes    4 Standard Finishes



PROJECT: \_\_\_\_\_  
 TYPE: \_\_\_\_\_



Dimensions and values shown are nominal. Spectrum Lighting continually works to improve products and reserves the right to make changes which may alter the performance or appearance of products.

# 6" SQUARE DIRECT

PAR SERIES / FIXTURE OPTIONS



## STANDARD FINISHES

**MW**  
MATTE WHITE

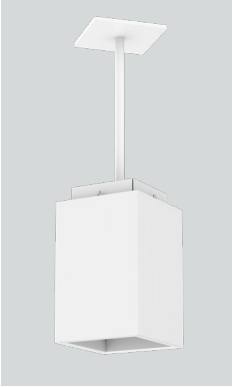

**MB**  
MATTE BLACK

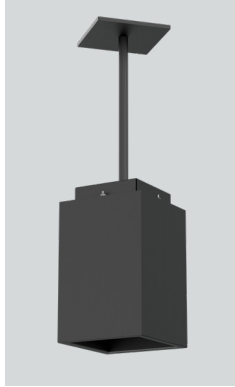

**PT**  
PLATINUM SILVER

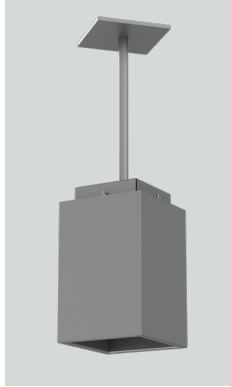

## MOUNTING TYPES

**HM / PM / AT**  
HANG STRAIGHT / PENDANT / ALL THREAD

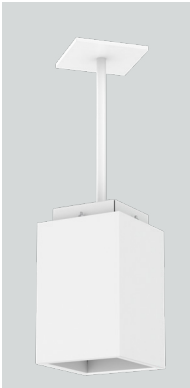

**CM**  
CORD MOUNT



**SM**  
SURFACE MOUNT





# STANDARD MOUNTING & ACCESSORIES

SOME OPTIONS NOT AVAILABLE ON ALL FIXTURES. CONSULT SPECIFICATION SHEETS. SEE INDIVIDUAL SPECIFICATION SHEETS OR CONSULT FACTORY FOR ADDITIONAL INFORMATION. NOTE: THIS IS TYPICAL OF CYLINDERS SPECIFICATION FOR PENDANT MOUNTING. INDIVIDUAL FIXTURES OR PROJECTS MAY HAVE SPECIALIZED REQUIREMENTS.

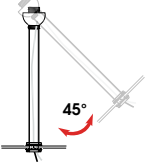
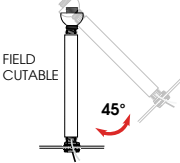
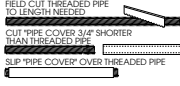
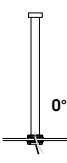

## MOUNTING TYPES

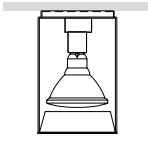
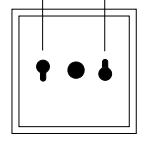
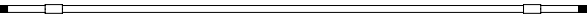
|                                                                                                                                                                                                                                                                                                                                                                                                                                                      |                                                                                                                                                                                                                                                                                                                                                                                                                                                                   |                                                                                                                                                                                                                                                                                                                                                                                                                                                       |                                                                                                                                                                                                                                                                                                                                                   |                                                                                                                                                                                                                                                                                                                                                                              |
|------------------------------------------------------------------------------------------------------------------------------------------------------------------------------------------------------------------------------------------------------------------------------------------------------------------------------------------------------------------------------------------------------------------------------------------------------|-------------------------------------------------------------------------------------------------------------------------------------------------------------------------------------------------------------------------------------------------------------------------------------------------------------------------------------------------------------------------------------------------------------------------------------------------------------------|-------------------------------------------------------------------------------------------------------------------------------------------------------------------------------------------------------------------------------------------------------------------------------------------------------------------------------------------------------------------------------------------------------------------------------------------------------|---------------------------------------------------------------------------------------------------------------------------------------------------------------------------------------------------------------------------------------------------------------------------------------------------------------------------------------------------|------------------------------------------------------------------------------------------------------------------------------------------------------------------------------------------------------------------------------------------------------------------------------------------------------------------------------------------------------------------------------|
| <p><b>HM*</b><br/>HANG STRAIGHT<br/>45° SWIVEL 1/2" STEM - 3/8" NPT</p>  <p>ORDER: <b>HM</b> (Length)<br/>SPECIFY LENGTH:<br/><b>HM3</b> - 3"    <b>HM24</b> - 24"<br/><b>HM6</b> - 6"    <b>HM36</b> - 36"<br/><b>HM12</b> - 12"    <b>HM48</b> - 48"<br/><b>HM18</b> - 18"    <b>HM72</b> - 72"<br/><b>HMLC(XX)</b><br/>Custom Length<br/>(Specify in Inches)</p> | <p><b>AT**</b><br/>HANG STRAIGHT ALL THREAD<br/>45° SWIVEL 1/2" STEM - 1/4" IP</p> <p>FIELD CUTTABLE</p>  <p>ORDER: <b>AT</b> (Length)<br/>SPECIFY LENGTH:<br/><b>AT12</b> - 12"<br/><b>AT24</b> - 24"<br/><b>AT36</b> - 36"<br/><b>ATLC(XX)</b><br/>Custom Length<br/>(Specify in Inches)</p>  | <p><b>PM*</b><br/>RIGID PENDANT MOUNT<br/>RIGID 1/2" STEM - 3/8" NPT</p>  <p>ORDER: <b>PM</b> (Length)<br/>SPECIFY LENGTH:<br/><b>PM3</b> - 3"    <b>PM24</b> - 24"<br/><b>PM6</b> - 6"    <b>PM36</b> - 36"<br/><b>PM12</b> - 12"    <b>PM48</b> - 48"<br/><b>PM18</b> - 18"    <b>PM72</b> - 72"<br/><b>PMLC(XX)</b><br/>Custom Length<br/>(Specify in Inches)</p> | <p><b>CD</b><br/>CORD / CABLE MOUNT<br/>SJ CORD WITH 1/16 SS CABLE</p>  <p>ORDER: <b>CD</b> (Length)<br/>SPECIFY LENGTH:<br/><b>CD36</b> - 36"<br/><b>CD72</b> - 72"<br/><b>CD144</b> - 144"<br/><b>CDLC(XX)</b><br/>Custom Length<br/>(Specify in Inches)</p> | <p><b>SM</b><br/>SURFACE MOUNT<br/>WIRING COMPARTMENT / TOP HAT</p>  <p>ORDER: <b>SM</b><br/>TOP VIEW CANOPY<br/>3.5</p>  <p>KEY SLOTS MOUNT CANOPY TO WALL JUNCTION BOX. JUNCTION BOX IS COVERED.</p> |
| <p>*MAXIMUM ONE PIECE STEM LENGTH IS 72". **MAXIMUM ONE PIECE STEM LENGTH IS 36". LONGER LENGTHS ARE POSSIBLE USING MULTIPLE STEMS AND COUPLERS.</p>                                                                                                                                                                                                                |                                                                                                                                                                                                                                                                                                                                                                                                                                                                   |                                                                                                                                                                                                                                                                                                                                                                                                                                                       |                                                                                                                                                                                                                                                                                                                                                   |                                                                                                                                                                                                                                                                                                                                                                              |

# COLOR OPTIONS - POWDER COAT PAINT FINISHES

NOTE: NO PRINTED IMAGE CAN EQUAL THE EXACT COLOR OF FINISH ON METAL.  
SEE INDIVIDUAL SPECIFICATION SHEETS OR CONSULT FACTORY FOR ADDITIONAL INFORMATION.



## STANDARD CORD / STEM / CANOPY FINISHES

| FIXTURE COLOR               | STANDARD CORD COLOR | STANDARD CANOPY / STEM COLOR |
|-----------------------------|---------------------|------------------------------|
| Matte White, Textured White | Matte White         | Matte White                  |
| Gloss White                 | Matte White         | Gloss White                  |
| Matte Black, Textured Black | Matte Black         | Matte Black                  |
| All Others                  | Matte Black         | Same Color as Fixture        |
| Custom Color                | Contact Factory     | Contact Factory              |

## PAINT TIMES

| TIER                       | COST            | AVERAGE PAINT TIME* |
|----------------------------|-----------------|---------------------|
| Tier 1 - Standard Finishes | \$              | ⌚                   |
| Tier 2 - Typical Finishes  | \$\$            | ⌚⌚                  |
| Custom Color               | Contact Factory | Contact Factory     |

\*CONTACT FACTORY FOR SPECIFIC PRODUCT LEAD TIMES

## TIER 1 - STANDARD FINISHES

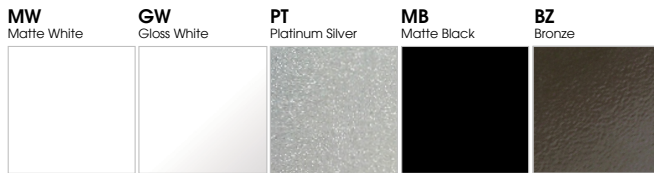

## TIER 2 - TYPICAL FINISHES

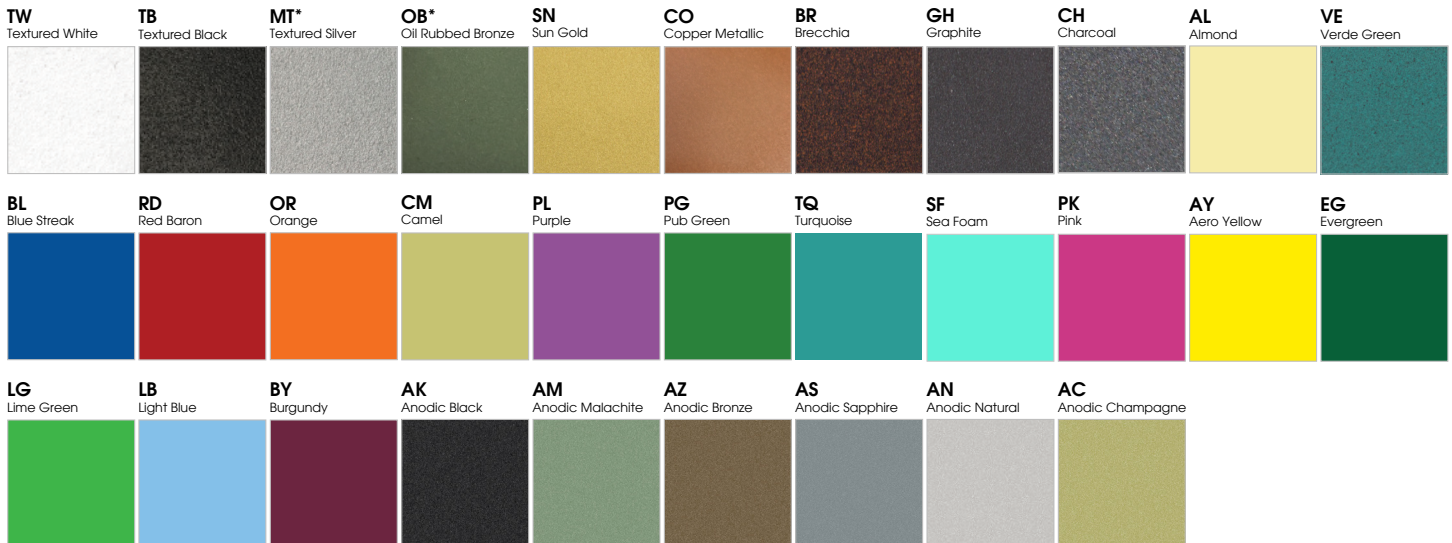

## CUSTOM COLOR FINISHES

CONTACT FACTORY

**CC**  
Custom Color



\*UNAVAILABLE FOR WET LOCATION