

8" HORIZONTAL FLUORESCENT SHALLOW OPEN WALL WASH

2 x 42 WATT MAX

8HF
SPECTRUM
SILVER SERIES™

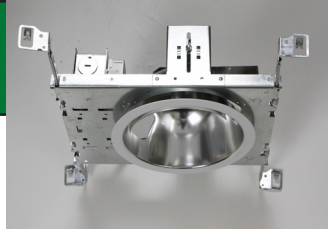

- 8" shallow horizontal lamp compact fluorescent.
- Available Wall wash.
- 20 gauge galvanized steel frame.
- 12" bar hangers expandable to 24" standard.
- .0625 spun aluminum reflector.
- Junction box pre-wired, grounded.
- Electronic ballast 120/277V standard.
- Ballast serviceable from the ceiling aperture.
- Suitable for use in damp location.
- UL listed to standard no. 1598

SIDE VIEW

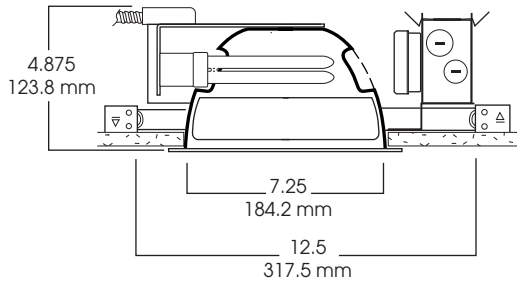

TOP VIEW

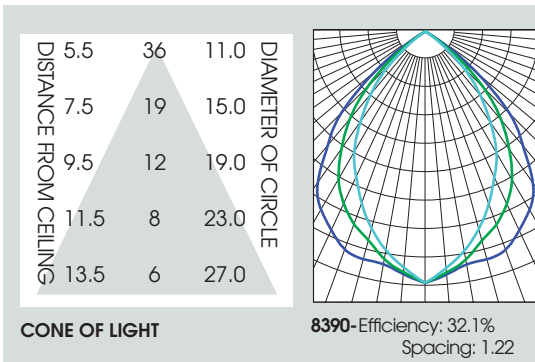
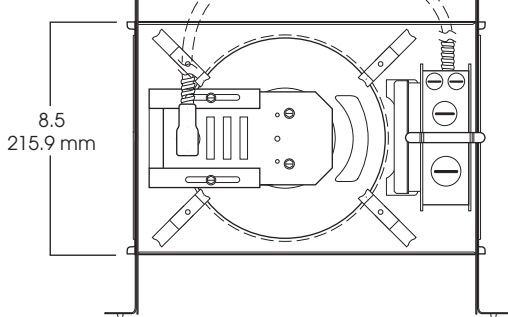

1. SPECIFY FRAME

FRAME	WATTS	BALLAST	OPTIONS
SPSW8HF	2 LAMP	EX -Electronic 120/277 (standard)	EM -Emergency battery pack (specify voltage)
Spectrum Silver 8"	13	DA1 -Advance Mark10™ dimming, 120v	FS -Fuse holder and fuse
Horizontal	18	DA2 -Advance Mark 10™ powerline dimming, 277v	PR -Plaster ring (pg 1-430)
	1 LAMP	DM7 -Advance MK7 Dimming 120/277	RM -Remodler housing
	13	DL1 -Lutron Compact SE™ 120v (min. dimming level 5%) ¹	BH27 -27" mounting bar
	18	DL2 -Lutron Compact SE™ 277v (min. dimming level 5%) ¹	TBC -T-bar clip
	26		
	32		
	42		
SPSW8HF	142	EX	

2. SPECIFY TRIM

OPEN WALL WASH

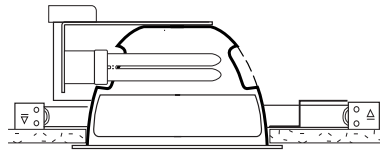

TRIM #	FINISH	OPTIONS
8390	SG -Soft Glow	PF -Polished
Open	CL -Clear Alzak	Flange
2 Quad	GO -Gold Alzak	BF -Black
	HZ -Haze	Flange
8395	PW -Pewter	BB -Black
Open	UM -Umber Alzak	Micro
1 TT	WE -Wheat Alzak	Baffle
8398	BL -Black Finish	WB -White
2TT	WH -White Finish	Micro
	PF -Polished	Baffle
	Flange	GS -Gasket
	BF -Black	
	Flange	
8390 SG		

3. FINISHED ORDER:

SPSW8HF132EX/8395 SG PF

Dimensions shown are nominal. Spectrum Lighting is continually improving products and reserves the right to make changes that will not alter performance or appearance with or without written notice.



PROJECT:	TYPE:
CAT. NO.:	

