

## FEATURES:

- Easy to install remodeling system.
- .063 Heavy gauge reflector, self flange/white flange standard.
- Frame with junction box (and ballast) fits into existing aperture
- Many finishes available on reflectors and flanges.
- Positive locking clips on frame to secure reflector.
- Options include extended whip length, dimming ballasts, emergency ballasts and 2 circuit wiring.
- Electronic ballast 120/277. -10%thd
- UL Listed
- Made in USA

# REMODELERS VERTICAL FLUORESCENT SPLIT FRAME STYLE

# SPRM SERIES

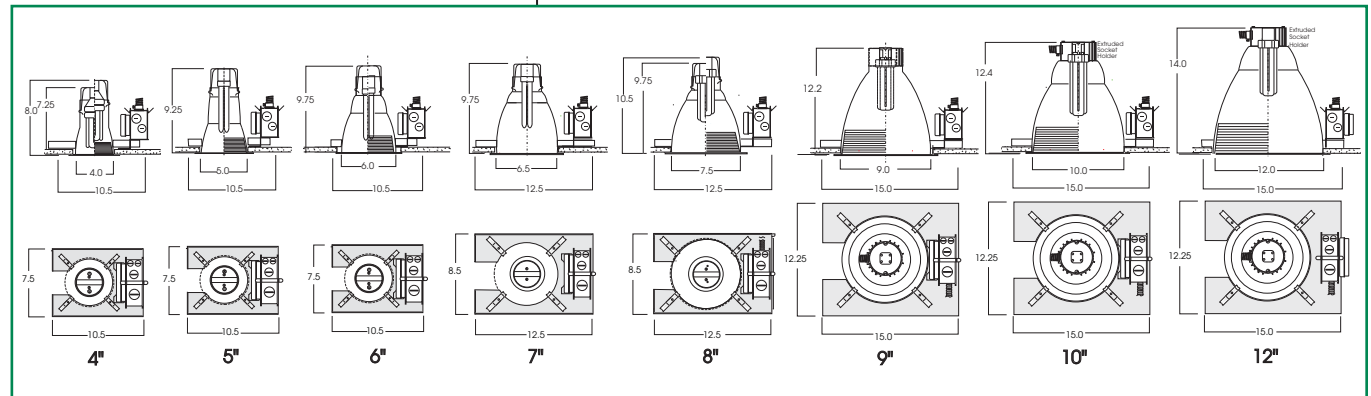
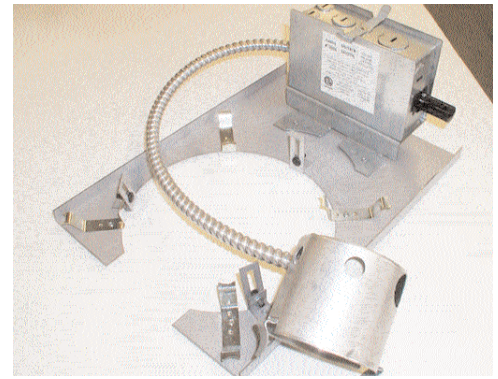

## ORDERING REMODEL FIXTURES

SIZE	SERIES	MAX WATTAGE	BALLAST	REFLECTOR
4"	SPRM4V 5" Aperture	1X18 Watt QPL 1X32 Watt TRT	EX- 120/277 V Electronic	4110 CL (OPEN)
5"	SPRM5V 5" Aperture	1X18 Watt QPL 1X32 Watt TRT	EX- 120/277 V Electronic	5310 CL (OPEN) 5220 PA (LENS)*
6"	SPRM6V 6" Aperture	1X32 Watt TRT	EX- 120/277 V Electronic	6410 CL (OPEN) 6420 PA (LENS)*
7"	SPRM7V 7" Aperture	1X42 Watt TRT	EX- 120/277 V Electronic	7110 CL (OPEN) 7120 PA (LENS)*
8"	SPRM8V 8" Aperture	1X42 Watt TRT	EX- 120/277 V Electronic	8110 CL (OPEN) 8120 PA (LENS)*
9"	SPRM9V 9" Aperture	1X57 Watt TRT	EX- 120/277 V Electronic	9110 CL (OPEN) 9120 PA (LENS)*
10"	SPRM10V 10" Aperture	1X70 Watt TRT	EX- 120/277 V Electronic	1010 CL (OPEN) 1020 PA (LENS)*
12"	SPRM12V 10" Aperture	2X70 Watt TRT	EX- 120/277 V Electronic	1210 CL (OPEN) 1220 PA (LENS)*

EXAMPLE:SPRM8V242EX/8610 CL

\* White splay with prismatic acrylic lens (PA) is standard on lensed CF fixtures

Dimensions shown are nominal. Spectrum Lighting is continually improving products and reserves the right to make changes that will not alter performance or appearance.



## SUBMITTAL WORKSHEET

MODEL NO.

JOB NAME.

FIXTURE TYPE



994 Jefferson Street . Fall River, MA 02721 . 508.678.2303 FAX 508.678.2260

P-RMHF-08