

# 8" HORIZONTAL MH SERIES OPEN/WALL WASH/LENS 100 WATT MAX

# H8MH SPECTRUM SILVER SERIES™

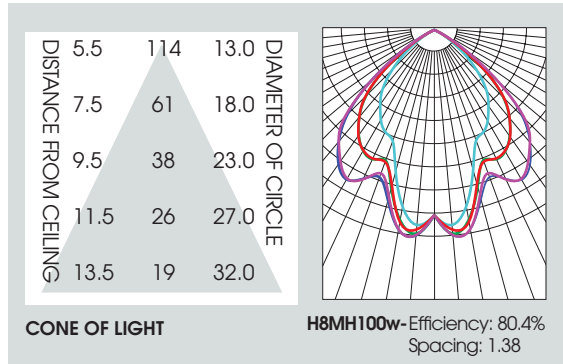

- 8" Metal halide horizontal down light series
- Available open, wall wash, and lens.
- 20 gauge galvanized steel frame.
- 12" bar hangers expandable to 24" standard.
- .0625 spun aluminum reflector.
- Junction box pre-wired, grounded.
- Electronic ballast 120/277V standard.
- Ballast serviceable from the ceiling aperture.
- Suitable for use in damp location. Lensed fixture has Wet Location option.
- UL listed to standard no. 1598.

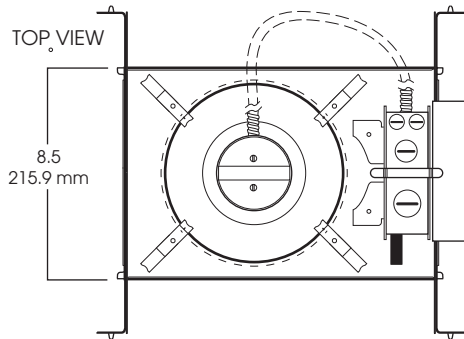
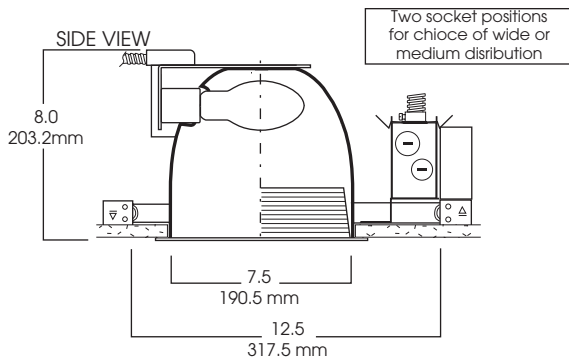

## 1. SPECIFY FRAME

FRAME	WATTS	BALLAST	LAMP	OPTIONS
<b>SPH8MH-</b> Spectrum Silver 8" Wall Wash Metal Halide	<b>50</b> <b>70</b> <b>100</b>	<b>EX-120/277</b>	<b>ED17</b> (50, 70, 100 WATT)	<b>FS</b> -Fuse holder and fuse <b>BH27</b> -27" Mounting Bars (2 per set) <b>PR</b> -Plaster Ring 1-430 <b>RM</b> -Remodeler Housing 1-450 <b>SCA</b> -Slope Ceiling Adaptor 1-435 <b>TBC</b> -T-bar clips 1-475 <b>QRS120</b> -Quartz Restrike-120v <b>QRS277</b> -Quartz Restrike-277v
<b>SPH8MH</b>	<b>100</b>	<b>EX</b>	<b>ED17</b>	<b>FS/</b>

## 2. SPECIFY TRIM

OPEN			LENSED		
TRIM #	FINISH	OPTIONS	TRIM #	SPLAY FINISH	LENS/OPTIONS
<b>8615</b> OPEN TRIM	<b>SG</b> -Soft Glow <b>CL</b> -Clear Alzak <b>GO</b> -Gold Alzak <b>HZ</b> -Haze <b>PW</b> -Pewter <b>UM</b> -Umber Alzak <b>WE</b> -Wheat Alzak <b>BL</b> -Black Finish <b>WH</b> -White Finish <b>PF</b> -Polished Flange	<b>PF</b> -Polished Flange <b>BF</b> -Black Flange <b>BB</b> -Black Micro Baffle <b>WB</b> -White Micro Baffle	<b>8625</b> LENSED TRIM	<b>WS</b> -White / White flange (standard) <b>SGS</b> -Soft Glow/ White flange <b>RB</b> -Regressed Black baffle White flange <b>RW</b> -Regressed White baffle White flange <b>PF</b> -Polished Flange <b>BF</b> -Black Flange	<b>PG</b> -Prismatic Glass lens (standard) <b>FG</b> -Frosted Glass <b>FL</b> -Fresnel Lens <b>GL</b> -Clear Glass lens <b>GS</b> -Gasket <b>WL</b> -Wet Location 1-470 <b>XB</b> -Cross Blade Louver
<b>8915</b> WALL WASH					
<b>8915 SG</b>		<b>PF</b>	<b>8625 SGS</b>		<b>PG</b>

## 3. FINISHED ORDER:

**SPH8MH100EX/8615 SG**

Dimensions shown are nominal. Spectrum Lighting is continually improving products and reserves the right to make changes that will not alter performance or appearance with or without written notice.



PROJECT:

TYPE:

CAT. NO.:

