

8" CYLINDER SERIES OPEN 8" ROUND

SPC08 SPECTRUM CYLINDERS

PAR 30/38 / ED17-100 WATT MAX MH



PRODUCT INFORMATION:

- 8" diameter cylinder series for use with open rated metal halide or high pressure sodium lamps.
- Extruded aluminum cylinder.
- PAR or ED17 lamps. (70 watt max electronic / 100 watt max magnetic).
- 20 color options.
- Canopy/wiring compartments at top of cylinder for surface and pendant mounting.
- Suitable for damp location.
- Manufactured and tested to UL standard No. 1598.

MOUNTING

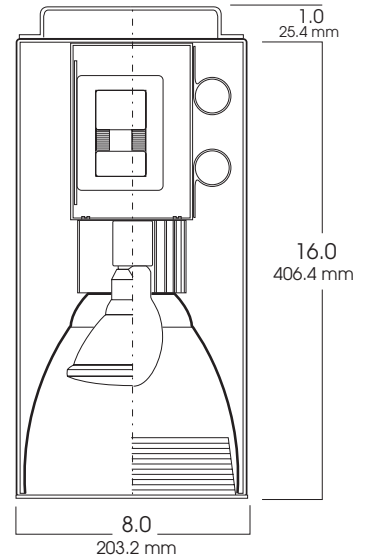
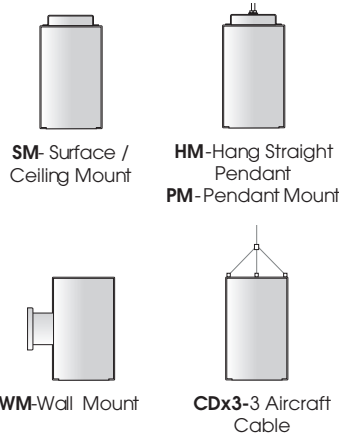

Fixture Weight: 8.5 lbs

DISTANCE FROM CEILING	DIAMETER OF CIRCLE
5.5	186
7.5	98
9.5	61
11.5	42
13.5	30

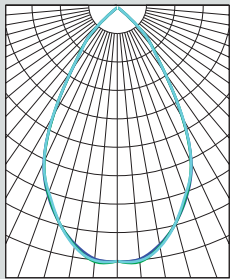

CONE OF LIGHT

100w-Efficiency: 64.2%
Spacing: 0.95

SERIES	WATTS	BALLAST	LAMP	OPTIONS	REFLECTOR	MOUNTING	FINISH
SPC0816MH- Spectrum Metal Halide Cylinder	39 50 70 100*	E1 -Electronic, 120v E2 -Electronic, 277v *H1 -Magnetic ballast, 120v *H2 -Magnetic ballast, 277v	ED17 PAR30 PAR38	FS -Fuse holder and fuse QRS -Quartz Re-Strike* GEM -Quartz Emergency Circuit *Specify Voltage 120v or 277v	8215-SG -Semi-Diffuse Low Iridescent CC -Custom Color BB -Black Micro Baffle WB -White Micro Baffle	HM* -Hang-Straight Mounting HMAT** -Field Cutable Length Hang Straight Pendant PM* -Pendant Mount SM -Surface Mount WM -Wall Mount CDx3 -3 Aircraft Cable & Cord * Specify Length in inches **12" or 36" lengths only See Cylinder Mounting Page for Aadditional Information	GW -Gloss White GB -Gloss Black MW -Matte White MB -Matte Black BZ -Bronze PT -Platinum Silver MT -Mini Tek Silver TW -Textured White CC -Custom Color
SPC0816MH	70	E1	ED17	FS	8215 SG	HM36	GW

* For High Pressure Sodium use HS

Dimensions shown are nominal. Spectrum Lighting is continually improving products and reserves the right to make changes that will not alter performance or appearance with or without written notice.



PROJECT:

TYPE:

CAT. NO.:

