

6" SQUARE CYLINDER SERIES OPEN 6" SQUARE PAR-150 WATT MAX INC

SPC06
SPECTRUM
CYLINDERS



PRODUCT INFORMATION:

- 6" square cylinder series for use with incandescent PAR lamps.
- Heavy gauge extruded aluminum square cylinder.
- 150 watt max incandescent.
- 20 powder coat options.
- Suitable for damp locations.
- 120 Volt standard.
- Manufactured and tested to UL standard No. 1598.

MOUNTING



SM- Surface / Ceiling Mount



HM-Hang Straight Pendant
PM-Pendant Mount

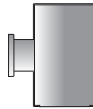

WM-Wall Mount

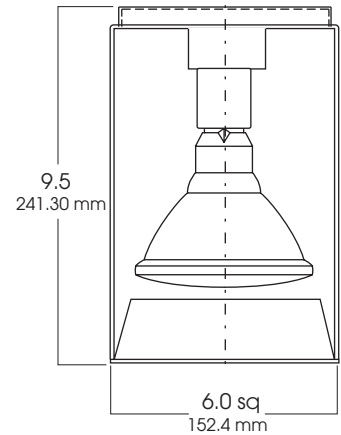

Fixture Weight: 4.5 lbs

DISTANCE FROM CEILING		DIAMETER OF CIRCLE
5.5	112	4.0
7.5	60	5.0
9.5	38	7.0
11.5	26	8.0
13.5	19	10.0

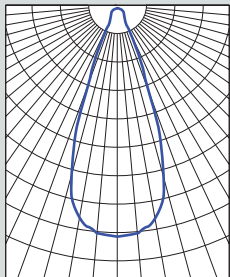

CONE OF LIGHT

100w- Efficiency: 94.6%
Spacing: 0.68

SERIES	LAMP	REFLECTOR	MOUNTING	FINISH
SPC0609SQINC - Spectrum Square Incandescent Cylinder	PAR20 PAR30 PAR38 R30	0305-SG -Semi-Diffuse Low Iridescent MW -Matte White MB -Matte Black	HM* -Hang-Straight Mounting HMAT** -Field Cutable Length Hang Straight Pendant PM* -Pendant Mount SM -Surface Mount WM -Wall Mount	GW -Gloss White GB -Gloss Black MW -Matte White MB -Matte Black BZ -Bronze PT -Platinum Silver MT -Mini Tek Silver TW -Textured White CC -Custom Color
SPC0609SQINC	PAR38	0305 SG	HM36	GW

* Specify Length in inches
**12" or 36" lengths only

See Cylinder Mounting Page
for Additional Information

Dimensions shown are nominal. Spectrum Lighting is continually improving products and reserves the right to make changes that will not alter performance or appearance with or without written notice.

SPECTRUM
LIGHTING, INC
www.speclight.com

PROJECT:

TYPE:

CAT. NO.:

