

# 6" CYLINDER SERIES OPEN 6" ROUND PAR-150 WATT MAX INC

**SPC06**  
**SPECTRUM**  
**CYLINDERS**



## PRODUCT INFORMATION:

- 6" diameter cylinder series for use with incandescent PAR lamps.
- Heavy gauge drawn aluminum cylinder.
- 150 watt max incandescent
- 20 powder coat options.
- Surface, pendant and wall mounting available.
- Suitable for damp locations.
- 120 Volt standard.
- Manufactured and tested to UL standard No. 1598.

## MOUNTING



**SM**- Surface / Ceiling Mount



**HM**-Hang Straight Pendant  
**PM**-Pendant Mount

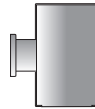

**WM**-Wall Mount

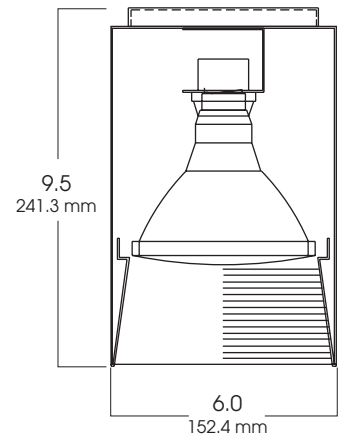

Fixture Weight: 2.25 lbs

DISTANCE FROM CEILING		DIAMETER OF CIRCLE
5.5	294	3.0
7.5	158	4.0
9.5	99	5.0
11.5	67	6.0
13.5	49	7.0

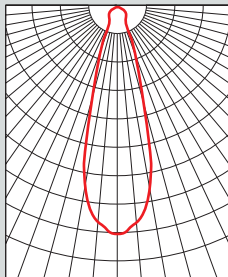

**CONE OF LIGHT**

150w-Efficiency: 90.2%  
Spacing: 0.50

SERIES	LAMP	REFLECTOR	MOUNTING	FINISH
<b>SPC0609INC-</b> Spectrum Incandescent Cylinder	<b>R30</b> <b>PAR30</b> <b>PAR38</b>	<b>6030-SG</b> -Semi-Diffuse Low Iridescent <b>WH</b> -White Finish <b>BB</b> -Black Micro Baffle <b>WB</b> -White Micro Baffle	<b>HM*</b> -Hang-Straight Mounting <b>HMAT**</b> -Field Cutable Length Hang Straight Pendant <b>PM*</b> -Pendant Mount <b>SM</b> -Surface Mount <b>WM</b> -Wall Mount	<b>GW</b> -Gloss White <b>GB</b> -Gloss Black <b>MW</b> -Matte White <b>MB</b> -Matte Black <b>BZ</b> -Bronze <b>PT</b> -Platinum Silver <b>MT</b> -Mini Tek Silver <b>TW</b> -Textured White <b>CC</b> -Custom Color
<b>SPC0609INC</b>	<b>PAR38</b>	<b>6030 SG</b>	<b>HM36</b>	<b>GW</b>

\* Specify Length in inches  
\*\*12" or 36" lengths only

See Cylinder Mounting Page  
for Additional Information

Dimensions shown are nominal. Spectrum Lighting is continually improving products and reserves the right to make changes that will not alter performance or appearance with or without written notice.



PROJECT:

TYPE:

CAT. NO.:

