

# 5" CYLINDER SERIES OPEN 5" ROUND PAR20-50 WATT MAX INC



## PRODUCT INFORMATION:

- 5" Cylinder Series for use with PAR16 and PAR20 lamps.
- Drawn aluminum cylinder.
- 50 watt max incandescent.
- 20 color options.
- Suitable for damp locations.
- 120 Volt Standard.
- Manufactured and tested to UL standard No. 1598.

## MOUNTING

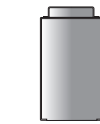

**SM**- Surface / Ceiling Mount



**HM**-Hang Straight Pendant  
**PM**- Pendant Mount

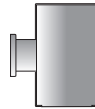

**WM**-Wall Mount

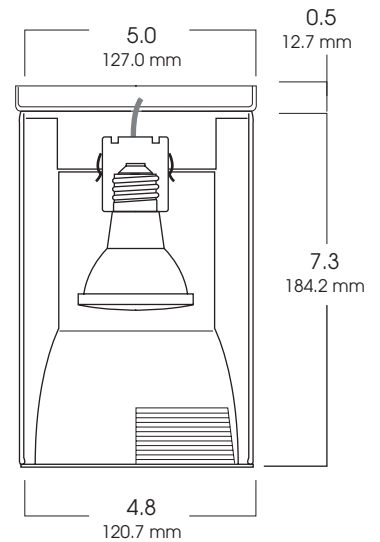

Fixture Weight: 5.0 lbs

DISTANCE FROM CEILING		DIAMETER OF CIRCLE
5.5	27	4.0
7.5	14	5.0
9.5	9	6.0
11.5	6	7.0
13.5	4	9.0

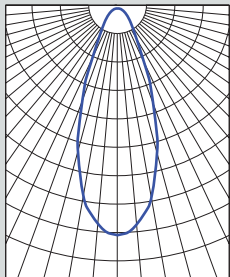

**CONE OF LIGHT**

50w-Efficiency: 87.5%  
Spacing: 0.64

SERIES	LAMP	REFLECTOR	MOUNTING	FINISH
<b>SPC0507INC-</b> Spectrum Round Incandescent Cylinder	<b>PAR16</b> <b>PAR 20</b>	<b>4415-SG</b> -Semi-Diffused Low Iridescent <b>BB</b> -Black Micro Baffle <b>WB</b> -White Micro Baffle * -Custom Finish (consult factory)	<b>HM*</b> -Hang-Straight Mounting <b>HMAT**</b> -Field Cutable Length Hang Straight Pendant <b>PM*</b> -Pendant Mount <b>SM</b> -Surface Mount <b>WM</b> -Wall Mount	<b>GW</b> -Gloss White <b>GB</b> -Gloss Black <b>MW</b> -Matte White <b>MB</b> -Matte Black <b>BZ</b> -Bronze <b>PT</b> -Platinum Silver <b>MT</b> -Mini Tek Silver <b>TW</b> -Textured White <b>CC</b> -Custom Color
<b>SPC0507INC</b>	<b>PAR 20</b>	<b>4415 SG</b>	<b>HM36</b>	<b>GW</b>

\* Specify Length in inches  
\*\*12" or 36" lengths only  
See Cylinder Mounting Page  
for Additional Information

Dimensions shown are nominal. Spectrum Lighting is continually improving products and reserves the right to make changes that will not alter performance or appearance with or without written notice.



<b>PROJECT:</b>	<b>TYPE:</b>
<b>CAT. NO.:</b>	

