

3" MINI ROUND CYLINDER OPEN 3" ROUND MR16-50 WATT MAX INC

SPC03
SPECTRUM
CYLINDERS



PRODUCT INFORMATION:

- 3" cylinder series provides direct and indirect lighting for use with MR16 lamps.
- Heavy gauge extruded aluminum cylinder.
- 50 watt max incandescent.
- 20 powder coat options.
- Suitable for damp locations. Wet location available.
- Consult factory for hang mount options.
- 120 Volt standard (E1). 277v option (E2).
- Manufactured and tested to UL standard No. 1598.

Fixture Weight: 2.00 lbs

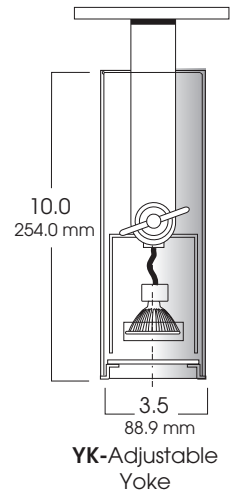
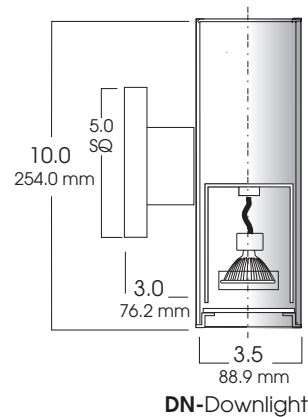
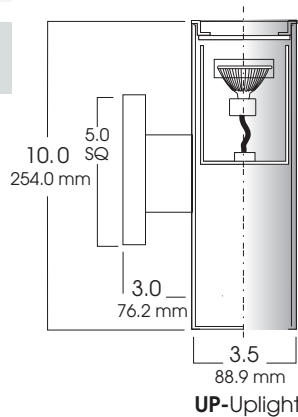
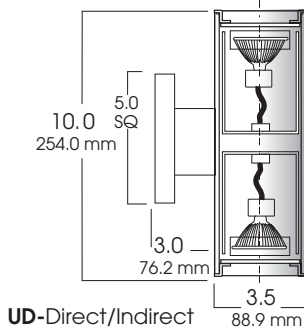

SERIES	LAMP	VOLTAGE	OPTIONS	MOUNTING	FINISH
SPC0310UDLV- Up/Down Cylinder	MR16	E1 -Electronic, 120v E2 -Electronic, 277v	FS -Fuse and Fuse Holder WL -Wet Location (Lensed/Gasketed)	WM -Wall Mount	GW -Gloss White GB -Gloss Black MW -Matte White MB -Matte Black BZ -Bronze PT -Platinum Silver MT -Mini Tek Silver TW -Textured White CC -Custom Color
SPC0310UPLV- Indirect Cylinder					
SPC0310DNLV- Direct Cylinder					
SPC0310YKLV- Adjustable Cylinder					
SPC0310UDLV	MR16	E1	WL	WM	GW

Dimensions shown are nominal. Spectrum Lighting is continually improving products and reserves the right to make changes that will not alter performance or appearance with or without written notice.

SPECTRUM
LIGHTING, INC
www.speclight.com

PROJECT:

TYPE:

CAT. NO.:

