



6" METAL HALIDE SERIES T4 / T6 LAMP 150 WATT MAX

A6SQMH
SPECTRUM
GOLD SERIES™

FEATURES & SPECIFICATIONS:

- EFEX² T4 / T6 Series MH Square aperture. Fixture features 45° adjustment from vertical with a 359° axial rotation.
- Intended for Non-IC new construction.
- Frame constructed of 20 ga. aluminum.
- Supplied with 27" long, heavy ga. galvanized steel bar hangers.
- Ballasts shall be integrally mounted, electronic sound rated "A", multi-volt 120v or 277v.
- UL Listed for Damp Locations.
- For options detail, see page numbers listed below.

Max Ceiling Thickness: 1.0 (25.4 mm)
Ceiling Cutout: 7.0² (177.8 mm)²
Fixture Weight: 7.0 lbs

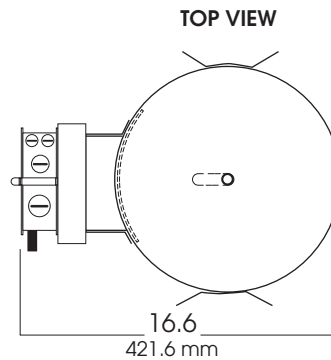
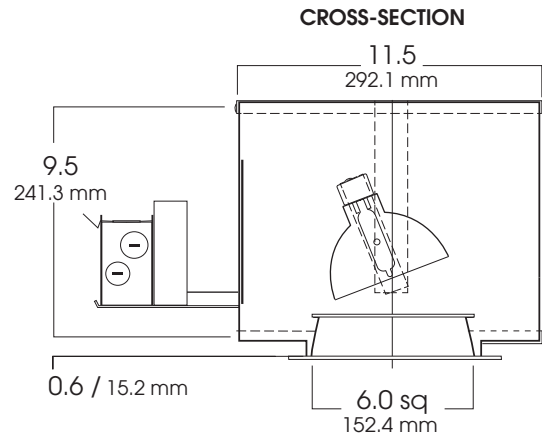

FIXTURE LAMPING

T4 - 20W thru 70W
T6 - 39W thru 150W

SERIES	WATTS	BALLAST	LAMP	DISTRIBUTION	OPTIONS	TRIM / FINISH	TRIM OPTIONS
SGA6SQMH- Spectrum Gold 6" Vertical Lensed Adjustable	20 39 70 150¹	EX -Electronic, multi-volt 120v or 277v E1 -Electronic 120v (150w only) E2 -Electronic 277v (150w only)	T4 T6	ND -Narrow MD -Medium WD -Wide	CB24 -C-Channel bars 1-470 CCEA -Chicago Ceiling Plenum CCEA 1-480 CR -Corrosion Resistant 1-460 FS -Fuse holder and fuse PR -Plaster Ring 1-430 TBC -T-bar clips 1-475 TR -Top Relamping Option QRS120 -Quartz Restrike-120v QRS277 -Quartz Restrike-277v	AR0306-SG -Semi-Diffuse Low Iridescent (standard) GM -Corrugated Soft Glow MB -Matte Black MW -Matte White PW -Pewter Alzak WE -Wheat Alzak BF -Black Flange WF -White Flange CC -Custom Color	GL -Clear Glass lens PG -Prismatic (T73) lens SO -Micro Prism Solite™ lens FG -Frosted Glass Lens GS -Gasket WL -Wet Location 1-470
SGA6SQMH	70	EX	T6	ND	CB24	AR0306 SG	GL

¹ Must specify voltage

Note: Polished flange is standard.

*For Available Decorative Architectural Trims, see page 1-490

Dimensions shown are nominal. Spectrum Lighting is continually improving products and reserves the right to make changes that will not alter performance or appearance with or without written notice.



PROJECT:	TYPE:
CAT. NO.:	

