



4" x 8" METAL HALIDE SERIES ADJUSTABLE DOWNLIGHT

2xCMH16 / 39 WATT MAX

A48SQ
SPECTRUM
GOLD SERIES™

FEATURES & SPECIFICATIONS:

- EFEX² Series Metal Halide Rectangular Aperture. Series fetures a shallow plenum housing.
- Intended for Non-IC new construction.
- Optional PZ48 fitter for flush to ceiling instilation.
- Frame constructed of 20 ga. galvanized steel.
- Supplied with 27" long, heavy ga. galvanized steel bar hangers.
- Ballasts shall be integrally mounted, electronic sound rated "A", multi-volt 120v or 277v.
- For options detail, see page numbers listed below.

Max Ceiling Thickness: 1.0 (25.4 mm)
Ceiling Cutout: 5.0 x 9.0
Fixture Weight: 7.9 lbs

CROSS-SECTION

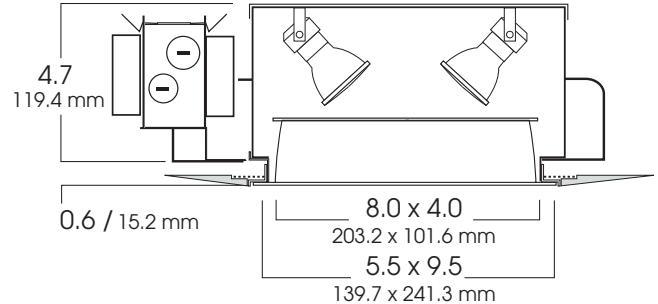

TOP VIEW

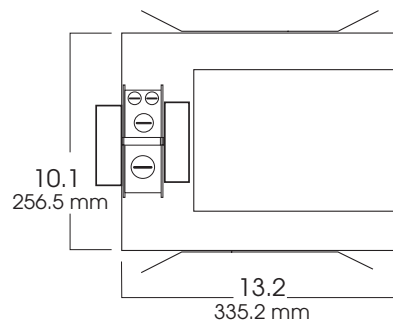

FIXTURE LAMPING

CMH16 - 2x20W
CMH16 - 2x39W

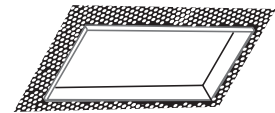

PZ FITTER WITH
PLASTER MESH
FLUSH FLANGE
INSTALLATION
OPTION

SERIES	WATTS	BALLAST	# / LAMP	OPTIONS	TRIM / FINISH	TRIM OPTIONS
SGA48SQ- Spectrum Gold 4"x8" Horizontal Adjustable Downlight	MH20 MH39	EX -Electronic, multi-volt 120v or 277v	2xCMH16¹	CB24 -C-Channel bars 1-470 CCEA -Chicago Ceiling Plenum CCEA 1-480 CR -Corrosion Resistant 1-460 FS -Fuse holder and fuse ADJL -Adjustable Lamp Bracket 2CIR -2 Circuit Wiring PZ48 -Flush Plaster Mesh Fitter 1-435	AR0208-SG -Semi-Diffuse Low Iridescent (standard) MB -Matte Black MW -Matte White PW -Pewter Alzak WE -Wheat Alzak CC -Custom Color NF -¼" Flush Flange (for use with PZ48)	PG -Prismatic Lens (standard) SO -Micro Prism Solite™ Lens GS -Gasket WL -Wet Location
SGA48SQ	MH20	EX	2XCMH16	PZ48	AR0208 MW NF	PG

¹ GX10 base

Note: Textured white flange is standard.

*For Available **Decorative Architectural Trims**, see page 1-490

Dimensions shown are nominal. Spectrum Lighting is continually improving products and reserves the right to make changes that will not alter performance or appearance with or without written notice.



PROJECT:	TYPE:
CAT. NO.:	

