

9" HORIZONTAL FLUORESCENT RADIAL DECORATIVE TRIM

2 x 42 WATT MAX



FEATURES & SPECIFICATIONS:

- SG9H features a radial decorative trim with frosted glass lens as standard.
- Intended for Non-IC new construction.
- Frame constructed of 20 ga. galvanized steel.
- Supplied with 27" long, heavy ga. galvanized steel bar hangers.
- Ballasts shall be integrally mounted, electronic, sound rated "A", Class P, multi-volt 120v-277v.
- UL Listed for Damp Locations.
- For options detail, see page numbers listed below.

Max Ceiling Thickness: 1.5 (38.1 mm)
 Ceiling Cutout: 9.4 Ø (238.8 mm Ø)
 Fixture Weight: 8.0 lbs

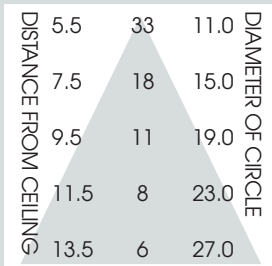

CONE OF LIGHT

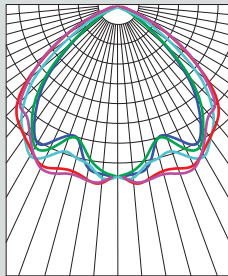

9H242w-Efficiency: 38.1%
Spacing: 1.34

CROSS-SECTION

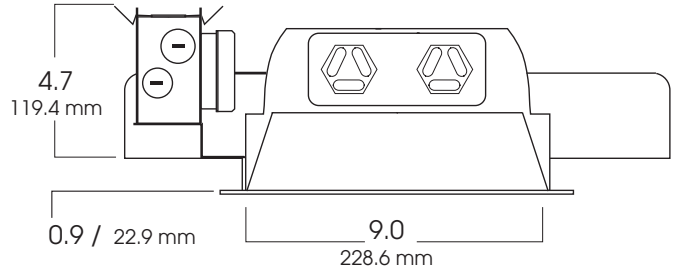

TOP VIEW

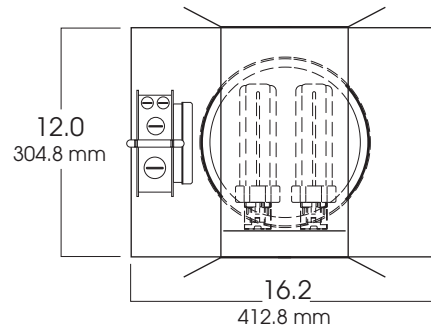

SERIES	WATTS ¹	BALLAST	OPTIONS	TRIM / FINISH
SG9H- Spectrum Gold 9" Horizontal	226 232 242	E1 -Electronic, 120v E2 -Electronic, 277v DA1 -Advance Mark 10™ powerline dimming, 120v DA2 -Advance Mark 10™ powerline dimming, 277v DAM7 -Advance Mark 7™ 0-10v dimming, 120v thru 277v DL1 -Lutron Compact SE™ 120v (min. dimming level 5%) DL2 -Lutron Compact SE™ 277v (min. dimming level 5%)	CB24 -C-Channel bars 1-470 CCEA -Chicago Ceiling Plenum CCEA 1-480 CR -Corrosion Resistant 1-460 EM -Emergency battery pack 1-420 FS -Fuse holder and fuse PR -Plaster Ring 1-430 RM -Remodeler Housing 1-450 TBC -T-bar clips 1-475 TP -Tampor Resistant TST -Twist-Lok Socket 1-425	AR9425FG-WH -White (standard) BA -Brushed Aluminum BR -Polished Brass BRB -Brushed Brass CR -Chrome GO -Gold CC -Custom Color
SG9H	242	E1	EM/	AR9425FG WH

¹ Triple Tube lamp

Dimensions shown are nominal. Spectrum Lighting is continually improving products and reserves the right to make changes that will not alter performance or appearance with or without written notice.



PROJECT:	TYPE:
CAT. NO.:	

