

# 4" METAL HALIDE SERIES OPEN REFLECTOR / BAFFLE 50 WATT MAX

**4MH**  
**SPECTRUM**  
**GOLD SERIES™**



## FEATURES & SPECIFICATIONS:

- 4 MH series features small aperture with medium cutoff.
- Intended for Non-IC new construction.
- Frame constructed of 20 ga. galvanized steel.
- Supplied with 27" long, heavy ga. galvanized steel bar hangers.
- Ballasts shall be integrally mounted, electronic sound rated "A", multi-volt 120v or 277v.
- UL Listed for Damp Locations.
- For options detail, see page numbers listed below.

Max Ceiling Thickness: 1.0 (25.4 mm)  
Ceiling Cutout: 4.2 Ø (106.7 mm Ø)  
Fixture Weight: 4.4 lbs

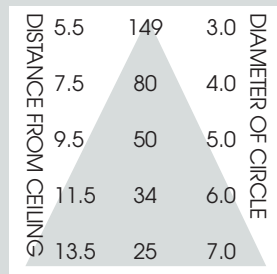

CONE OF LIGHT

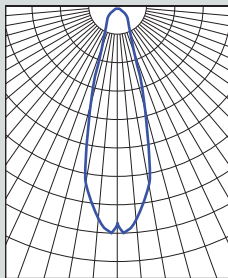

4MH39w-Efficiency: 90.9%  
Spacing: 0.54

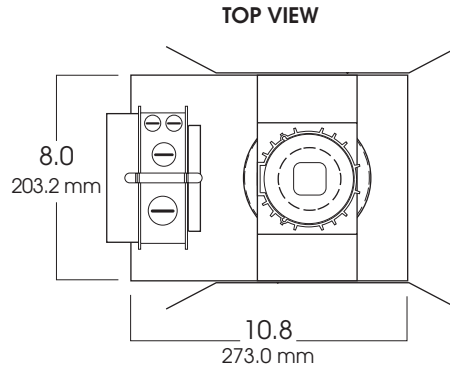
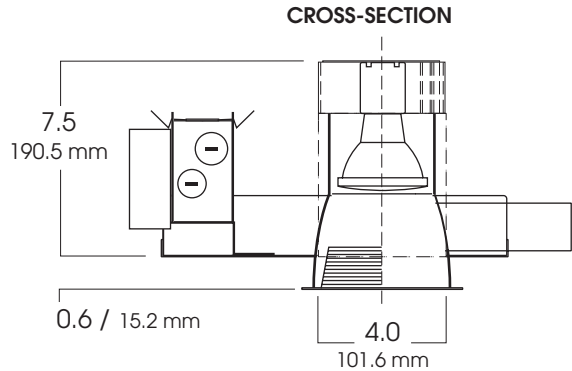

## FIXTURE LAMPING

**CMH16 - 20W**  
**ED17 - 50W**  
**PAR20 - 20W, 39W**

SERIES	WATTS	BALLAST	LAMP	OPTIONS	TRIM / FINISH	TRIM OPTIONS
<b>SG4MH-</b> Spectrum Gold 4" Vertical	<b>20</b> <b>39</b> <b>50</b>	<b>EX</b> -Electronic, multi-volt 120v or 277v	<b>CMH16<sup>1</sup></b> <b>ED17<sup>3</sup></b> <b>PAR20<sup>2</sup></b>	<b>CB24</b> -C-Channel bars 1-470 <b>CCEA</b> -Chicago Ceiling Plenum CCEA 1-480 <b>CR</b> -Corrosion Resistant 1-460 <b>FS</b> -Fuse holder and fuse <b>PR</b> -Plaster Ring 1-430 <b>RM</b> -Remodeler Housing 1-450 <b>TBC</b> -T-bar clips 1-475	<b>AR4415-SG</b> -Semi-Diffuse Low Iridescent (standard) <b>CL</b> -Clear Bright Alzak <b>GO</b> -Gold Alzak <b>HZ</b> -Matte Low Iridescent <b>PW</b> -Pewter Alzak <b>UM</b> -Umber Alzak <b>WE</b> -Wheat Alzak <b>BL</b> -Black Finish <b>WH</b> -White Finish <b>PF</b> -Polished Flange	<b>GS</b> -Gasket <b>BB</b> -Black Micro Baffle <b>WB</b> -White Micro Baffle
<b>SG4MH</b>	<b>20</b>	<b>EX</b>	<b>PAR20</b>	<b>CB24</b>	<b>AR4415 SG</b>	<b>GS</b>

<sup>1</sup> GX10 base  
<sup>2</sup> Medium base  
<sup>3</sup> Open Rated only

Note: White flange is standard.

\*For Available  
**Decorative  
Architectural Trims,**  
see page 1-490

Dimensions shown are nominal. Spectrum Lighting is continually improving products and reserves the right to make changes that will not alter performance or appearance with or without written notice.



**PROJECT:** \_\_\_\_\_ **TYPE:** \_\_\_\_\_

**CAT. NO.:** \_\_\_\_\_

