



4" INCANDESCENT DOWNLIGHT OPEN REFLECTOR / BAFFLE 100 WATT MAX

4IN
SPECTRUM
GOLD SERIES™

FEATURES & SPECIFICATIONS:

- Small aperture series with deep cutoff.
- Intended for Non-IC new construction.
For IC applications, refer to page 1-400.
- Frame constructed of 20 ga. galvanized steel.
- Supplied with 27" long, heavy ga. galvanized steel bar hangers.
- **120 Volt** is standard. Use option **T277** for 277v supply feed.
- UL Listed for Damp Locations.
- For options detail, see page numbers listed below.

Max Ceiling Thickness: 1.5 (38.1 mm)
Ceiling Cutout: 4.2 Ø (108.0 mm Ø)
Fixture Weight: 4.0 lbs

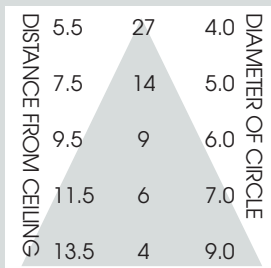

CONE OF LIGHT

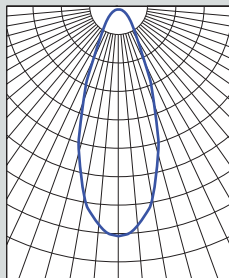

4IN50w - Efficiency: 87.5%
Spacing: 0.64

CROSS-SECTION

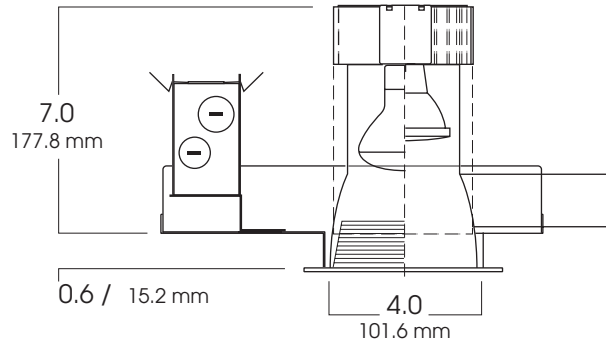

TOP VIEW

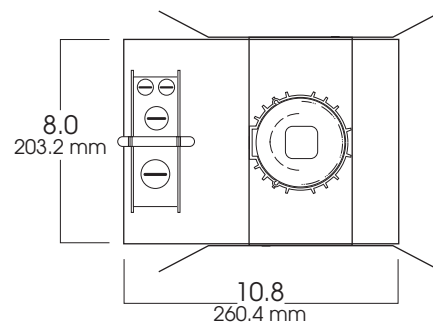

SERIES	OPTIONS	TRIM / FINISH	TRIM OPTIONS	FIXTURE LAMPING*								
SG4IN- Spectrum Gold 4" Vertical	CB24 -C-Channel bars 1-470 CCEA -Chicago Ceiling Plenum CCEA 1-480 CR -Corrosion Resistant 1-460 FS -Fuse holder and fuse IC -Insulation Contact 1-400 PR -Plaster Ring 1-430 RM -Remodeler Housing 1-450 TBC -T-bar clips 1-475 TR -Top Relamping Option T277 -Step down Transformer 277v to 120v	AR4415-SG -Semi-Diffuse Low Iridescent (standard) CL -Clear Bright Alzak GO -Gold Alzak HZ -Matte Low Iridescent PW -Pewter Alzak UM -Umber Alzak WE -Wheat Alzak BL -Black Finish WH -White Finish PF -Polished Flange	GS -Gasket BB -Black Micro Baffle WB -White Micro Baffle	<table border="1"> <thead> <tr> <th>LAMP</th> <th>MAX. WATTAGE</th> </tr> </thead> <tbody> <tr> <td>A 19</td> <td>100w</td> </tr> <tr> <td>PAR 20</td> <td>50w</td> </tr> <tr> <td>R 20</td> <td>100w</td> </tr> </tbody> </table> <p>*Medium Base</p>	LAMP	MAX. WATTAGE	A 19	100w	PAR 20	50w	R 20	100w
LAMP	MAX. WATTAGE											
A 19	100w											
PAR 20	50w											
R 20	100w											
SG4IN	CB24	AR4415 SG	WB									

Note: White flange is standard.

*For Available **Decorative Architectural Trims**, see page 1-490

Dimensions shown are nominal. Spectrum Lighting is continually improving products and reserves the right to make changes that will not alter performance or appearance with or without written notice.



PROJECT:	TYPE:
CAT. NO.:	

