



10" SQUARE INDUCTION SERIES OPEN REFLECTOR 165 WATT MAX

10SQDU
SPECTRUM
GOLD SERIES™

FEATURES & SPECIFICATIONS:

- Optic arrangement precisely directs light and optimizes output.
- Induction system technology- 100,000 hrs. rated life.
- Clear tempered safety glass lens optional.
- Intended for Non-IC new construction.
- Frame constructed of 18 ga. galvanized steel.
- Supplied with 27" long, heavy ga. galvanized steel bar hangers.
- High frequency generator, -9% THD.
- Manufactured and tested to UL standard No. 1598. ETL Listed.
- For options details, see page numbers listed below.

Max Ceiling Thickness: 1.0 (25.4 mm)
Ceiling Cutout: 11.0² (279.4 mm)²
Fixture Weight: 12.0 lbs

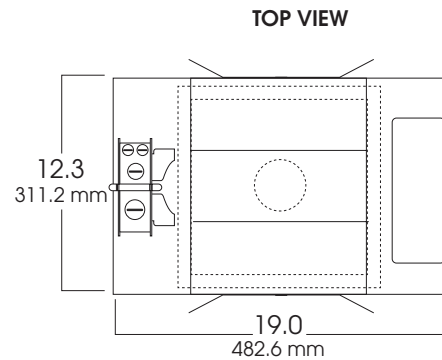
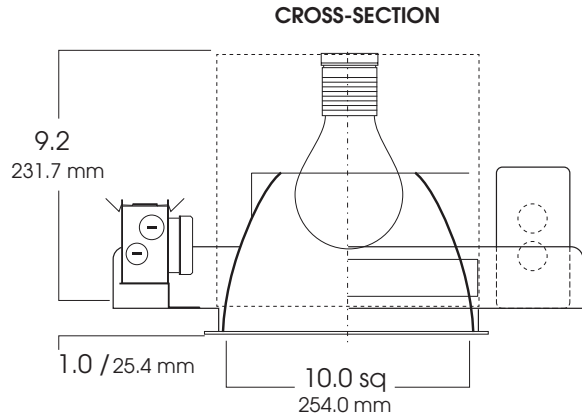

SERIES	WATTS	KELVIN°	GENERATOR	OPTIONS	TRIM / FINISH	TRIM OPTIONS
SG10SQDU- Spectrum Gold 10" Vertical Square Induction System Downlight	55 85 165	3K -3000° Kelvin 4K -4000° Kelvin	G1 -QL Generator 120v G2 -QL Generator 277v	CB24 -C-Channel bars 1-470 CR -Corrosion Resistant 1-460 FS -Fuse holder and fuse PR -Plaster Ring 1-430 TBC -T-bar clips 1-475	AR1116-SG -Semi-Diffuse Low Iridescent (standard) WF -White Flange BF -Black Flange MB -Matte Black MW -Matte White	GS -Gasket GL -Clear Glass lens
SG10SQDU	55	3K	G1	CB24	AR1116 SG	GS

Note: Polished flange is standard.

Dimensions shown are nominal. Spectrum Lighting is continually improving products and reserves the right to make changes that will not alter performance or appearance with or without written notice.



PROJECT:	TYPE:
CAT. NO.:	

