

LARGE DOCK LIGHT

CF / INC / MH

RLM SERIES



PRODUCT INFORMATION:

- 16" diameter Large Dock Light Series.
- Fixture is constructed of die cast aluminum.
- Compact fluorescent, metal halide and incandescent lamping available.
- Standard fixture wet location listed.
- Manufactured and built to UL standard No 1598.

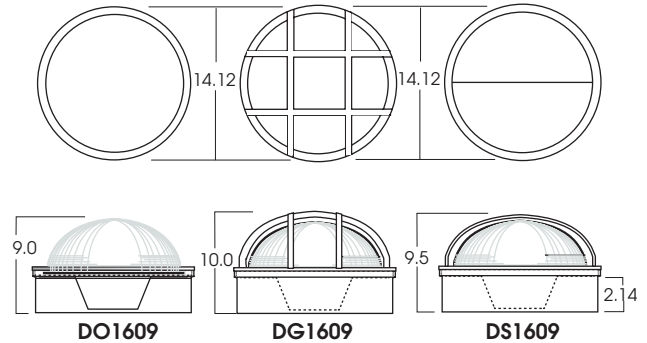

MODEL	WATTS	BALLAST	OPTIONS	MOUNTING	FINISH
DO1609CF- LENS ONLY	(1 to3) 18/26/32/42	EX - Electronic 120/277v (18/26/32/42)	FS -Fusing Option EM1 -Emergency Ballast 120v (internal 120v) EM2 -Emergency Ballast 277v (internal 277v)	SM -Surface Mount	MW -Matte White MB -Matte Black BZ -Bronze CC -Custom Color
DG1609CF- LENS/GRILLE	(1 to3) 18/26/32/42				
DS1609CF- LENS/EYELID	(1 to3) 18/26/32/42				
DO1609MH- LENS ONLY	50/70/100	EX - Electronic 120/277v (50/70/100)			
DG1609MH- LENS/GRILLE	50/70/100				
DS1609MH- LENS/EYELID	50/70/100				
DO1609INC- LENS ONLY	200w				
DG1609INC- LENS/GRILLE	200w				
DS1609INC- LENS/EYELID	200w				
DO1609CF	26	EX	EM1	SM	MW

Dimensions shown are nominal. Spectrum Lighting is continually improving products and reserves the right to make changes that will not alter performance or appearance with or without written notice.

PROJECT:	TYPE:
CAT. NO.:	

