



INFINIUM™ LUMEN MAX
HEAVY METAL LED
 21 / 42 / 63 WATTS LED

HMI-LED
LUMEN MAX
SERIES

PRODUCT INFORMATION:

- Spectrum Lighting Heavy Metal flood light.
- Die Cast aluminum housing with powder coat finish.
- 50,000 hours rated LED system life.
- All LED modules and drivers are replaceable and up-gradeable.
- Damp Location listed. Wet Location available.
- Manufactured and tested to UL standard No. 1598.

HMI1212LED
AREA LIGHT

KELVIN°	WATTAGE	LUMENS
31K°	21W	1400
	42W	2800
	63W	4200
35K°	21W	1550
	42W	3100
	63W	4650
41K°	21W	1610
	42W	3220
	63W	4830
51K°	21W	1680
	42W	3360
	63W	5040

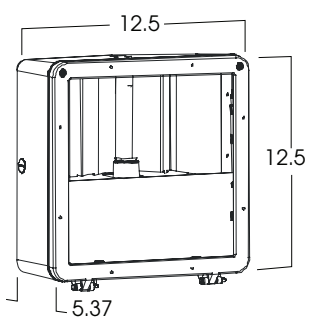

MOUNTING COMPONENTS



MODEL	LED	KELVIN	VOLTAGE	OPTIONS	MOUNTING	FINISH
HMI1212LED- 12" X 12" LED Area Fixture	21w 42w 63w	31K -3100° Kelvin 35K -3500° Kelvin 41K -4000° Kelvin 51K -5000° Kelvin	E1 -Electronic, 120v E2 -Electronic, 277v	FS -Fusing OCC -Occupancy Sensor PHO -Photo Sensor URS -IR Occupancy & Photo Sensor (Inside Fixture) 2CIR -2 circuit WL -Wet Location	TBK -Trunion Bracket PF3 -Pole Fitter 3" EX6 -6" Extender Arm EX10 -10" Extender Arm EX12 -12" Extender Arm	BZ -Bronze MW -Matte White CC -Custom Color
HMI1212LED	63W	51K	E1	URS	TBK	BZ

Dimensions shown are nominal. Spectrum Lighting is continually improving products and reserves the right to make changes that will not alter performance or appearance with or without written notice.



PROJECT: _____ **TYPE:** _____

CAT. NO.: _____

