

WARNING:
 BE CERTAIN ALL POWER IS OFF.
 WIRE ACCORDING TO LOCAL AND NATIONAL
 CODES. THIS PRODUCT SHOULD BE INSTALLED
 BY A QUALIFIED ELECTRICIAN

1. WITH HOUSING INSTALLED, LEVEL AND WITH NECESSARY POWER CONNECTIONS MADE, ATTACH SOCKET TO MR16 LAMP,

NOTE: FIXTURE HAS EXTRA LONG SOCKET WIRE FOR EASE OF RE-LAMPING. (Fig.1)

2. INSTALL LAMP/LENS INTO LAMP HOLDER. (ACCEPTS UP TO 2 MEDIA-FOR 3 MEDIA CONSULT FACTORY) (Fig.1)

3. INSTALL LAMP CUP INTO FIXTURE ADJUSTMENT BRACKET. (Fig.2)

NOTE FIXTURE ADJUSTMENT BRACKET IS ARCHED TO ALLOW MAINTAINED CENTER BEAM FOCUS FROM 0° TO 45°.

LAMP CUP MAY BE ROTATED AT ANY TIME TO CREATE SPECIAL BEAM PATTERNS (SEE SPECTRUM LENS PAGE)

(Fig.2a)

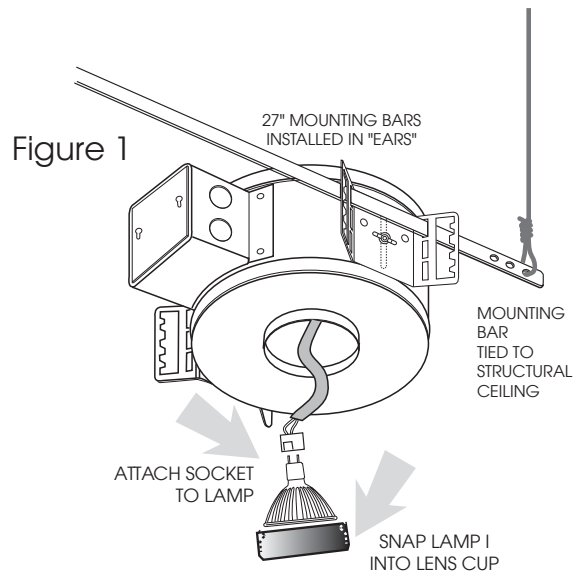

Figure 2

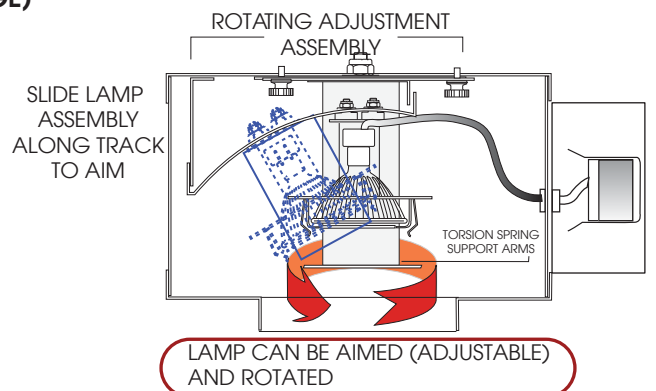
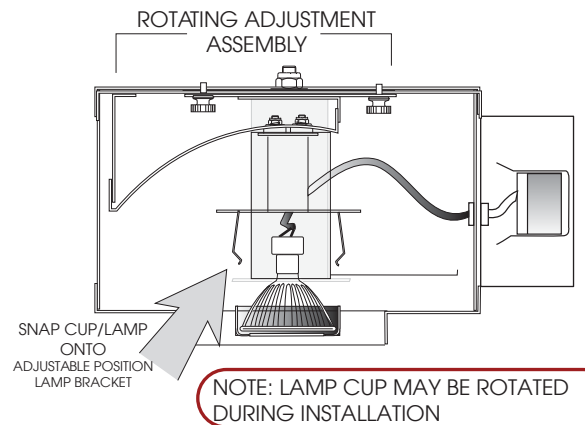

Figure 2a

WARNING:
BE CERTAIN ALL POWER IS OFF.
WIRE ACCORDING TO LOCAL AND NATIONAL
CODES. THIS PRODUCT SHOULD BE INSTALLED
BY A QUALIFIED ELECTRICIAN

4. ADJUST ANGLE OF LAMP ALONG ARCH EITHER BY HAND OR WITH FLAT HEAD SCREWDRIVER. (Fig.3)

NOTE: SPECIAL TEFLON BUSHINGS MAINTAIN ANGLE WITHOUT LOCKING REQUIRED.

5. ROTATE ENTIRE AIMING ASSEMBLY INTO APPROXIMATE POSITION BEFORE INSTALLING TRIM.
5. COMPRESS TORSION SPRINGS AT SIDES ON INSERT CONE, INSERT THROUGH SLOTS IN ARMS ON ROTATING ASSEMBLY. (Fig.4)

Figure 4



ALLOW EXPANDING SPRINGS TO DRAW TRIM UP INTO FIXTURE UNTIL TRIM IS FLUSH WITH CEILING.

6. ROTATE TRIM TO DESIRED ANGLE. NOTE: ENTIRE LAMP ASSEMBLY WILL MOVE WITH TRIM MAKING IT EASY TO AIM TRIM AND LAMP AS A UNIT.
7. MAKE FINAL ADJUSTMENTS.

Figure 3

AIMING

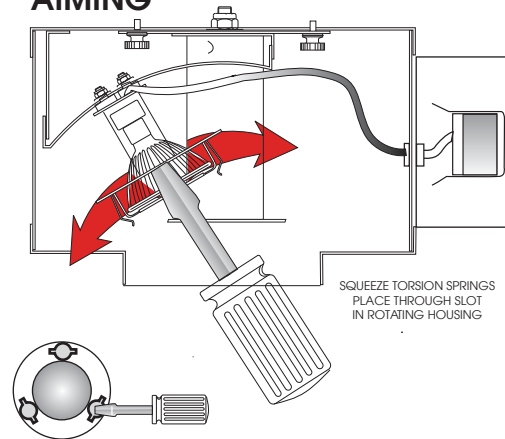

Figure 4
TRIM

TORSION SPRING BRACKET ROTATES WITH LAMP ASSEMBLY

